

These instructions apply to all models listed.  
Details and procedures unique to a specific model are labeled appropriately.

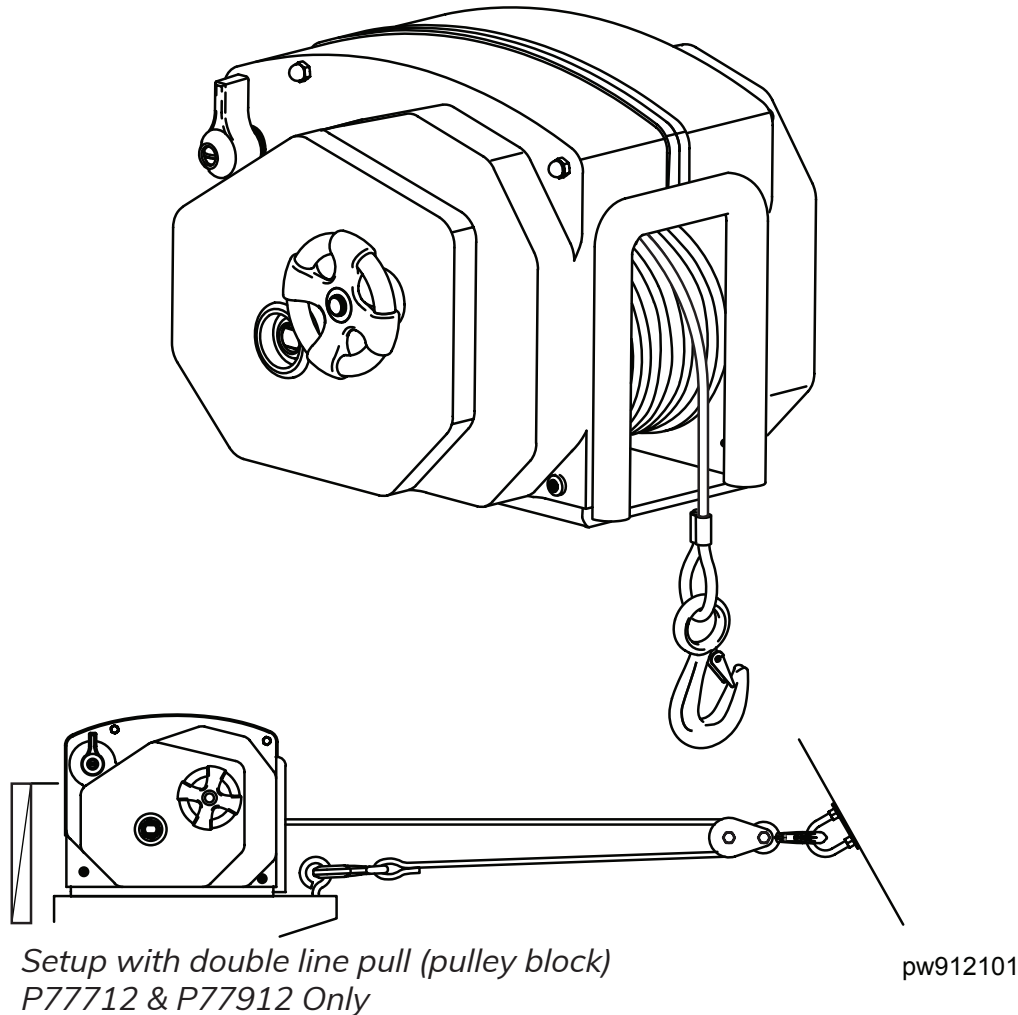

- ◆ 12 Volt Powered Winch
- ◆ Power-in / Freewheel-out Operation



Thoroughly read manual furnished with this product and be familiar with controls. Do not allow individuals to operate winch without understanding safe operation and procedures for equipment.

# PROPRIETARY STATEMENT

The Powerwinch Trailer Winch is a product of Scott Fetzer Electrical Group or SFEG, located in Fairview, Tennessee, USA. The information contained or disclosed in this document is considered proprietary to SFEG. Every effort has been made to ensure that the information presented in this document is accurate and complete. However, SFEG assumes no liability for errors or any damages resulting from the use of this document.

The information contained in this manual pertains to the current configuration of the models listed on the title page. Earlier model configurations may differ from the information given. SFEG reserves the right to cancel, change, alter or add any parts and assemblies, described in this manual, without prior notice.

SFEG agrees to allow the reproduction of this document for use with SFEG products only. Any other reproduction or translation of this document in whole or part is strictly prohibited without prior written approval from SFEG.

# TABLE OF CONTENTS

<b>SAFETY INFORMATION</b> .....	<b>iii</b>
<b>SPECIFICATIONS</b> .....	<b>iv</b>
WINCH SPECIFICATIONS.....	iv
APPROXIMATE ROLLING LOAD CAPACITIES (VALUES ARE IN POUNDS).....	iv
WINCH & BOAT CAPACITIES (VALUES ARE IN POUNDS).....	iv
<b>INSTALLATION</b> .....	<b>1</b>
MOUNTING UNIT.....	1
WIRING UNIT.....	2
ASSEMBLY PULLEY BLOCK.....	3
DOUBLE LINING WINCH (P77712 & P77912 ONLY).....	3
<b>OPERATION</b> .....	<b>4</b>
UNLOADING BOAT.....	4
LOADING BOAT.....	5
EMERGENCY HAND CRANK.....	5
<b>MAINTENANCE</b> .....	<b>6</b>
LUBRICATION.....	6
REPLACING CABLE.....	6
REPLACING STRAP.....	7
TROUBLESHOOTING GUIDE.....	8
<b>ILLUSTRATED PARTS LIST</b> .....	<b>9</b>
<b>WARRANTY</b> .....	<b>11</b>

## SAFETY INFORMATION

The following Safety Precautions Must be followed at ALL Times. Failure to follow the warnings and cautions in this manual could result in serious injury and/or property damage.

### **WARNING**

This product can expose you to chemicals including Di-isodecyl phthalate (DIDP), Vinyl Chloride and Cumene, which are known to the state of California to cause cancer or birth defects or other reproductive harm. For more information visit [www.P65warnings.ca.gov](http://www.P65warnings.ca.gov).

### **CAUTION**

ALWAYS block vehicle wheels to help prevent vehicle from moving when pulling a load with winch.

### **CAUTION**

SHOCK HAZARD. ALWAYS unplug wire harness before attempting to install, relocate, service or perform maintenance on winch.

### **CAUTION**

NEVER use winch to lift or move people or animals.

### **CAUTION**

NEVER use winch for overhead lifting.

### **CAUTION**

NEVER attempt to pull a load greater than rated load of winch.

### **CAUTION**

ALWAYS stand away from winch during operation. To avoid personal injury and property damage, clear area around and behind boat of people, animals and obstructions before loading or unloading boat. Serious injury could occur if cable breaks.

### **CAUTION**

NEVER wear loose fitting clothes, scarves, ties or jewelry when operating winch. Loose clothing can become caught in moving parts.

### **CAUTION**

ALWAYS keep hands clear of cable spool (drum area).

### **CAUTION**

ALWAYS wear leather gloves when handling cable. Steel cable can cause serious damage to hands.

### **CAUTION**

ALWAYS remove all tools used for manual override operation before operating winch with electrical power.

### **CAUTION**

NEVER use winch alone to secure boat to trailer during transit. Use separate straps or equivalent to secure boat to trailer.

### **CAUTION**

ALWAYS stand away from winch during operation. ALWAYS stand clear of area behind and between load and winch. Serious injury could occur if cable breaks.

# SPECIFICATIONS

Various load conditions affect winch performance. The line pull required for a specific application depends on the weight of the load, condition of the trailer rollers, and the degree of the loading ramp incline. The charts below are based on a single line pull and provided as a guideline in calculating pulling capabilities.

**⚠ WARNING** Cable fasteners on this or any winch are not designed to hold rated loads independently. ALWAYS leave a minimum of five wraps of cable on drum to achieve rated load values.

## WINCH SPECIFICATIONS

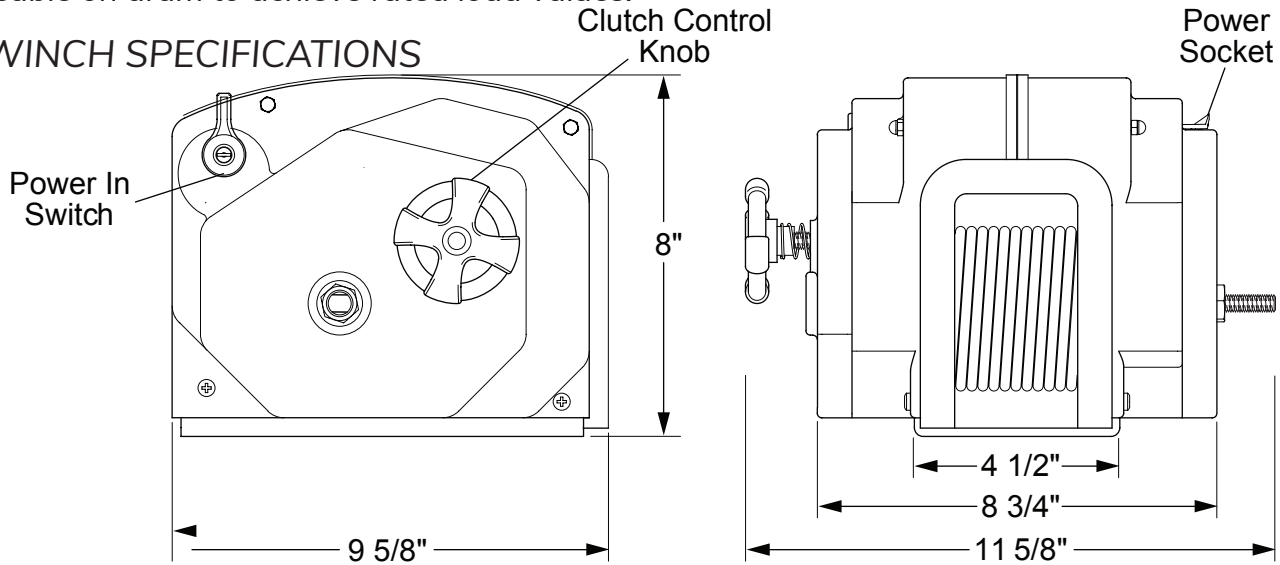

PW912001

Model	Part Number	Line Speed @ Capacity (FPM)	Gear Ratio	Voltage	Circuit Breaker	Unit Weight
712	P77712	14	225: 1	12 VDC	60 amps	33 lbs.
712-S	P77712-S	14	225: 1	12 VDC	60 amps	23 lbs.
912	P77912	8	450: 1	12 VDC	60 amps	35 lbs.

## APPROXIMATE ROLLING LOAD CAPACITIES (VALUES ARE IN POUNDS)

% Incline	Level	5%	10%	20%	30%	50%	70%	100%
Incline	0°	3°	6°	11°	17°	26°	35°	45°
712	24000	13340	10040	6800	5220	3720	3060	2580
912	40000	23345	17570	11900	9135	6510	5355	4515

- A 10% incline (6°) is 1 foot rise in 10 feet.
- To convert from pounds (lbs) to kilograms (kgs) divide by 2.2.
- Capacity can be increased by using a pulley block.

## WINCH & BOAT CAPACITIES (VALUES ARE IN POUNDS)

Model	Part Number	Vertical Lift Capacity	Double Line Pull	Approximate Boat Weight*	Approximate Boat Size*
712	P77712	2400	4300	7500	17-23 Feet
712-S	P77712-S	2000	N/A	6250	17-23 Feet
912	P77912	4000	7500	11500	23-30 Feet

\* Boat size and weight is approximate and varies depending on boat type. When calculating boat weight, use the fully loaded weight that includes boat, motor, fuel, water, gear etc.

## INSTALLATION

### MOUNTING UNIT

The following instructions are for standard mounting of winch. Winch can be mounted on trailer in same position and location as an existing hand winch.

1. Remove existing hand winch.
2. Position unit on trailer mount stand.
3. Confirm that winch's cable hook and bow eye on boat are at same height when boat is in fully loaded position on trailer. If bow eye is too high, extra pull is required of winch and extra stress is exerted on boat's stern and bow eye.  
If necessary to create equal height, raise or lower winch stand. In most cases, trailer manufacturers have adapters available for use with a winch.
4. Confirm that there is a minimum of 12 inches clearance between winch and bow eye when boat is in fully loaded position. If necessary, extend bow stop to obtain clearance.
5. Bolt unit using a minimum of two (2)  $\frac{3}{8}$ " grade 5 machine bolts and lock nuts. If existing mounting holes do not line up with winch, use the bottom of winch as a template and drill two (2)  $\frac{7}{16}$ " holes in mounting surface of trailer stand.
6. If using a double line pull (using a pulley block), install a  $\frac{3}{8}$ " eyebolt on stand as close as possible to base of winch. See illustration on page 3. Pulley block comes with P77712 & P77912 only.

**⚠ WARNING** SHOCK HAZARD. ALWAYS disconnect battery before working on electrical equipment.

**⚠ WARNING** ALWAYS use recommended wire size and rated circuit breakers. Failure to use furnished and recommended sizes can cause a fire hazard and void warranty.

**NOTICE** When routing wiring, AVOID sources of heat.

**NOTICE** When routing wiring, AVOID sharp edges that can cut or fray wire insulation.

WIRING UNIT

The following instructions are for permanently wiring the winch.

1. Attach circuit breaker to battery's POSITIVE (+) post or positive (+) terminal of starter solenoid.
2. Attach ground wire (black) to vehicle frame. Clean metal frame with a wire brush or equivalent then attach ground lug using a 5/16" bolt and lock nut (bolt and nut not furnished).
3. Route wire under vehicle and along the frame. Avoid sharp edges and moving parts. Secure wire to frame approximately every 18" using nylon ties or equivalent.

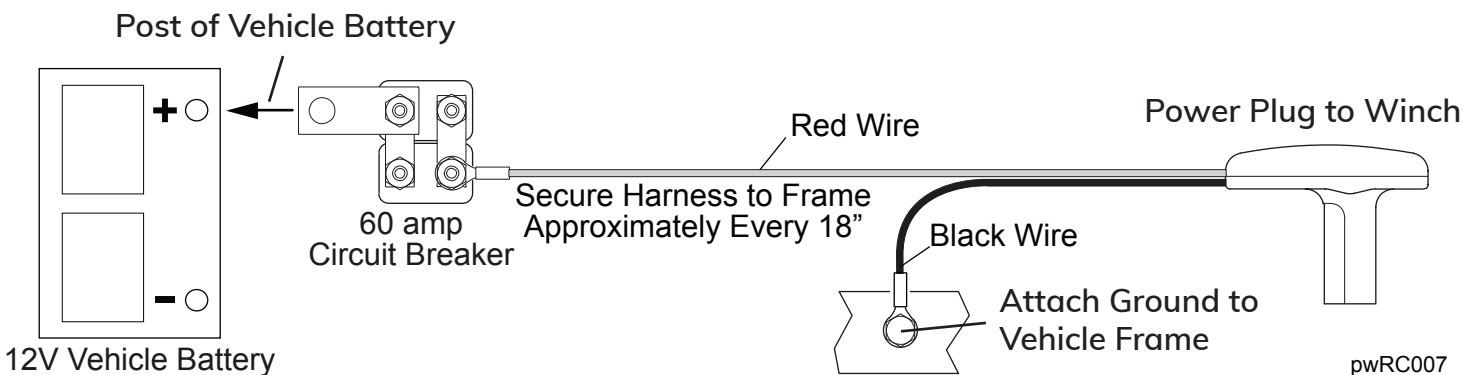

## ASSEMBLING PULLEY BLOCK

Pulley block can increase the pulling capacity approximately 55%.

1. Place two screws through one tear drop plate and hold in place.
2. Slide a bushing over each screw.
3. Slide pulley wheel and hook over bushings as shown. Components fit loosely on bushings.
4. Wrap cable around pulley.
5. Place second tear drop plate over screws and secure using washers and nuts provided.
6. Mount an eyebolt next to winch. Eyebolt should be mounted as close to winch as possible.

Only included with P77712 and P77912

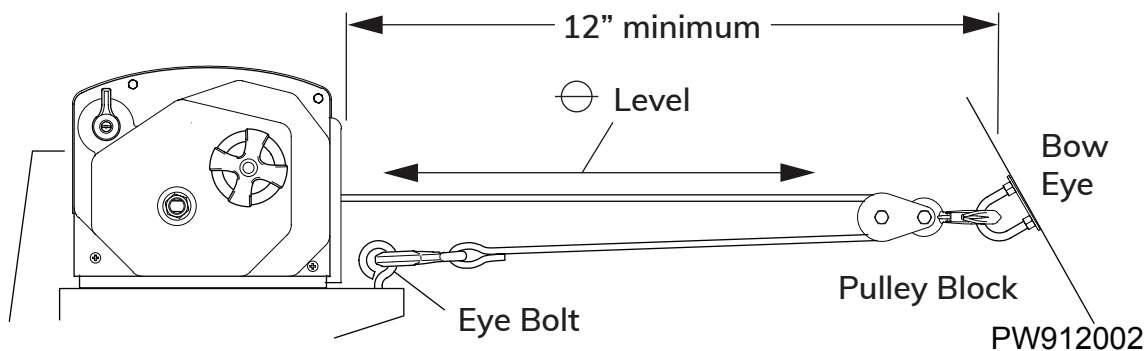
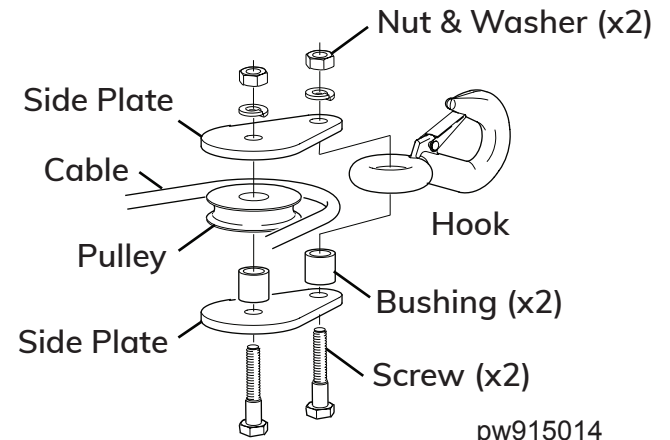

## DOUBLE LINING WINCH

1. With cable threaded through block, hook pulley block to eye on bow.
2. Power out cable and attach cable hook to eyebolt next to winch.
3. Power in cable.

OPERATION

**⚠ WARNING** To avoid personal injury and property damage, ALWAYS clear area around and behind boat of people, animals and obstructions before loading or unloading boat.

**⚠ WARNING** NEVER stand between load or anchor point and winch. Serious personal injury could occur if cable breaks.

**⚠ WARNING** NEVER use winch alone to secure boat to trailer during transit. Use separate straps or equivalent to secure boat to trailer.

**⚠ CAUTION** ALWAYS wear leather gloves when handling cable. Steel cable can cause serious damage to hands.

**NOTICE** After using winch, ALWAYS disconnect power cord from socket to avoid moisture collection in socket and prevent possibility of short circuiting.

**NOTICE** DO NOT operate winch continuously for periods over 20 minutes to prevent damage to motor. Allow motor to “rest” for a minimum of 1 hour.

UNLOADING BOAT

1. Attach hook to bow eye on boat.
2. Connect wire harness to winch. Plug goes into socket on right side of winch.
3. Remove tie down straps from boat.
4. Slowly turn clutch knob counterclockwise to release winch brake.
5. Allow boat to slide off trailer. If necessary, clutch knob can be tightened to slow speed of boat.
6. When boat is in water, release hook.
7. Tighten clutch knob clockwise until finger tight to set brake.
8. While maintaining tension on cable/strap, press switch on winch. Roll cable/strap up completely. DO NOT allow cable/strap to roll up loosely, damage to cable/strap and winch components could occur.

**NOTICE** DO NOT allow hook to roll into winch. Damage to level wind plate can occur.

9. Secure hook to prevent any accidental injury or damage.

Power In Switch

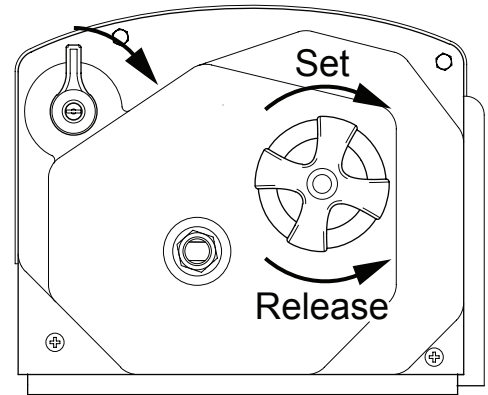

PW912003



## LOADING BOAT

1. Align boat and trailer.
2. Loosen clutch knob, turn counterclockwise and free-wheel cable/strap to boat. Attach hook to bow eye.
 

**NOTE:** If cable/strap is initially difficult to pull out, try engaging motor for a few seconds with clutch fully released. This should free clutch allowing hook to pull out.
3. Tighten clutch knob clockwise until finger tight to set brake. **DO NOT** over tighten clutch knob; over tightening can cause damage to clutch.
4. Step clear of cable/strap and boat.
5. Press and hold switch. Power in cable/strap until boat touches bow stop. Release button. Secure boat to trailer.

## EMERGENCY HAND CRANK

An emergency hand crank is available when there is no power (i.e. a dead battery).

**⚠ WARNING** NEVER use hand crank to assist a running motor. Serious personal injury can occur.

1. Disconnect wire harness from winch.
2. Tighten clutch knob clockwise until finger tight to set brake. **DO NOT** over tighten clutch knob; over tightening can cause damage to clutch.
3. Remove jam nut from shaft on right side of winch.
4. Place emergency handle onto shaft and secure to shaft with nut removed previously. Tighten nut snugly against handle.
5. Turn crank handle to wind in cable. Clockwise for 912, counterclockwise for 712 and 712-S.
6. After boat has been secured on trailer, remove handle from shaft. Replace nut on shaft.
7. Store handle.

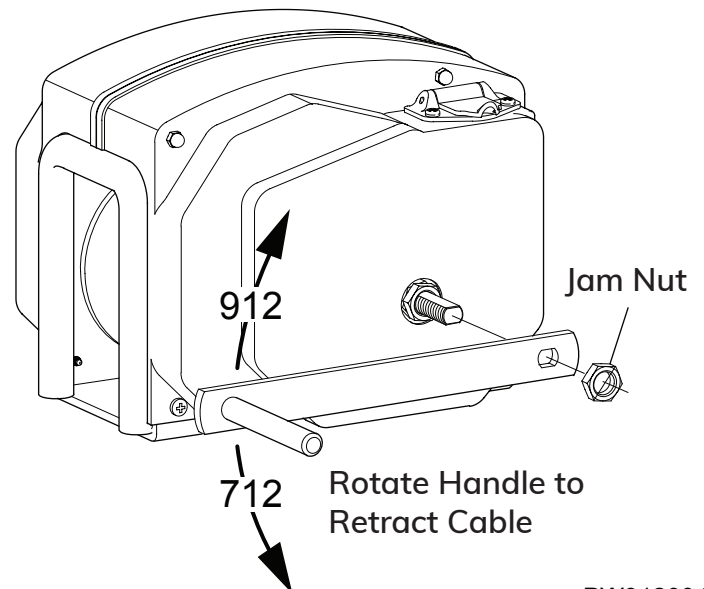

PW912004

**⚠ CAUTION** ALWAYS remove all tools used for manual override operation before operating winch with electrical power.

## MAINTENANCE

### LUBRICATION

The following steps should be performed a minimum of once a year or when unit is placed in storage.

**Cable:** Lubricate cable with Whitmore's Wire Rope Spray, WD40 or equivalent. Spray shaft and cable as cable is being wound. P77712 & P77912 only.

**Gears:** Remove covers and lubricate the gears with a lithium base grease. Be careful not to get grease on clutch lining refer to figure on page 9.

### REPLACING CABLE



## WARNING

ALWAYS use exact Powerwinch replacement cable (p/n P7188800AJ). Winch rating and cable strength are matched for safe and optimum performance. NEVER replace cable with unapproved parts.



## CAUTION

ALWAYS wear leather gloves when handling cable. Steel cable can cause serious damage to hands.

1. Disconnect wire harness.
2. Loosen clutch knob, turn counterclockwise and free-wheel cable completely out.
3. Cut old cable off approximately 2" from cable drum.
4. Slide collar away from cable then push old cable out of drum shaft.
5. Insert new cable through shaft. Cable must be inserted through side opposite counter bore.
6. Insert stop sleeve over end of cable until cable is flush with end of stop. Solder or crimp stop onto cable.
7. Pull cable back through shaft until stop is seated in counter bore of hole.
8. Slide collar around cable. Notch on collar fits around cable.
9. Tighten clutch knob clockwise until finger tight to set brake. DO NOT over tighten clutch knob; over tightening can cause damage to clutch.
10. Reconnect wire harness to unit. Power-in cable, keeping tension on cable as it is winding. Cable must wind from top of cable spool.

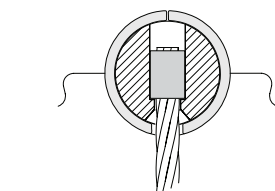
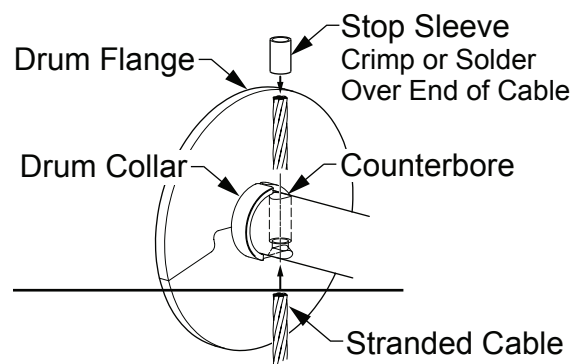

Completed Installation pwRC013

## NOTICE

NEVER wound cable incorrectly, it may cause loss of power and risk damage to level wind plate. If cable is not correct too loose or wound on one side, unwind cable then rewind while keeping tension on cable.

## REPLACING STRAP

**CAUTION** ALWAYS use exact Powerwinch replacement strap (P/N P71892). Winch rating and strap strength are matched for safe and optimum performance. NEVER replace strap with unapproved strap.

1. Disconnect wire harness from winch.
2. Loosen clutch knob, turn counterclockwise, and free-wheel strap completely out.
  - a. If removing cable, please refer to steps 3 & 4 in REPLACING CABLE Section on page 6.
  - b. If replacing cable with strap, the drum collar and level wind plate must be removed. Remove cover and with a punch and hammer remove level wind plate. After level wind plate is removed use pliers and/or prybar to bend off drum collar from spool shaft.
3. Loosen and remove bolts with  $\frac{5}{32}$ " Allen key and remove strap, lock washers, and strap plate.
4. Grab the non-hook looped side of new strap, fold in edges of loop to allow adequate clearance for bolt holes in strap plate (P/N P55302).
5. Insert Strap Plate into loop, and with fold seam of strap facing downward and the winch facing toward operator, place bolts through holes in strap plate.
6. Place split lock washer(s) on bottom side of plate (i.e., washers should be between shaft and plate).
 

NOTE: Make sure split of lock washer is facing toward exterior of winch to avoid tearing strap while under load.
7. Using  $\frac{5}{32}$ " Allen key, tighten bolts down.
 

NOTE: Screw each bolt until finger tight and then tighten in small increments switching from bolt to bolt as to allow strap to tighten evenly and avoid uneven strap plate installation.
8. Tighten clutch knob, turn clockwise until snug to set brake.
 

DO NOT over tighten clutch knob; over tightening can cause damage to clutch.
9. Reconnect wire harness to unit. Power-in strap, keeping tension on strap as it is winding. Strap must wind from top of cable spool.

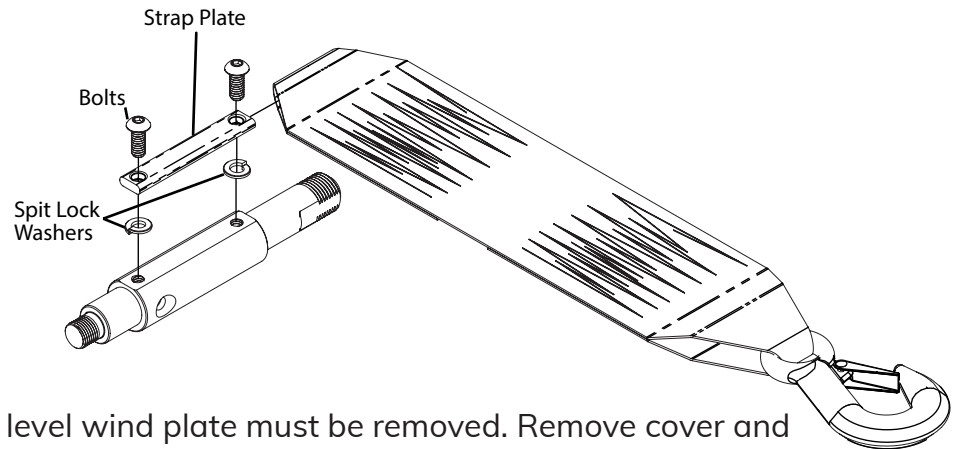

TROUBLESHOOTING GUIDE

Winch Does Not Operate			
A.	Confirm power to winch. 1. Check vehicle battery is fully charged. 2. Confirm connections are tight & clean. 3. Check wires are worn or bare that may cause shorts.		Correct as required.
B.	Check circuit breaker at battery.  Bypass circuit breaker and test winch. Does winch run?		
	<div style="border: 2px solid black; padding: 2px; display: inline-block;"><b>NOTICE</b></div> DO NOT operate the winch without circuit breaker. Removing circuit breaker from circuit is ONLY for testing.	YES	If winch runs, circuit breaker is bad, replace.
		NO	Reconnect circuit breaker. Contact your authorized service center.
Load Slips			
A.	Load slips during retrieval.	Thrust washers and thrust bearings are worn or deformed. Replace.	
B.	Load slips back after boat is retrieved.	Clutch bearing inside the 120 tooth gear has failed. Replace gear assembly.	
C.	Check clutch lining.		
	Clutch lining is located on 120 tooth gear under the LHS (clutch side) of case. Ensure that clutch is clean and free of grease.	Clean as required. If clutch lining is worn or damaged, replace the 120 tooth gear assembly.	
Cable Difficult to Pull Out			
A.	If winch cable is initially difficult to pull out, try engaging motor for a few seconds with clutch fully released. This should free clutch allowing cable to pull out.		

ILLUSTRATED PARTS LIST

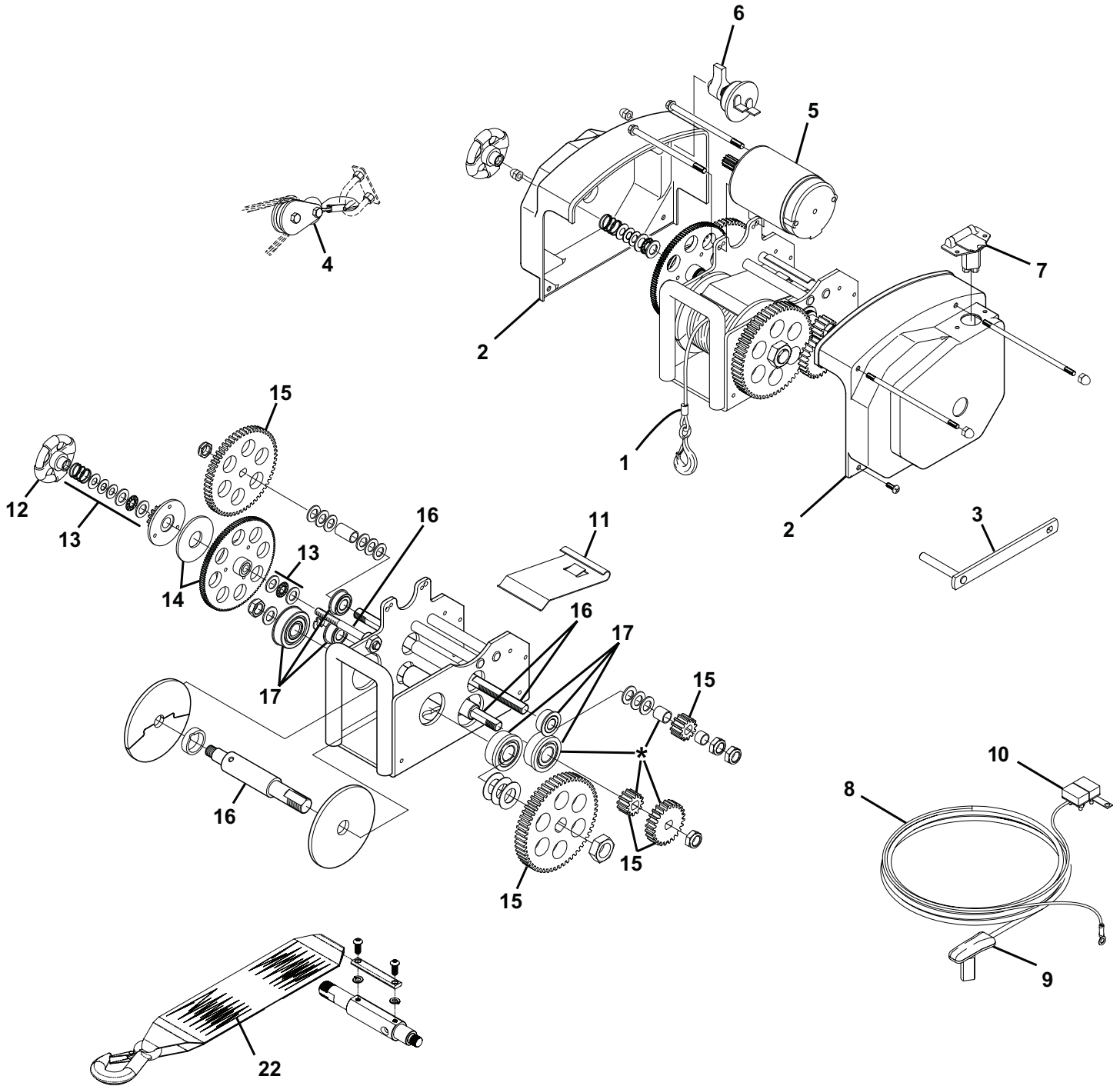

pw912501

Please refer to the table on page 10 to determine if shown items are used with your model.

# Powerwinch

# 712, 712-S, & 912 Trailer Winch

<i>Item</i>	<i>712</i>	<i>712-S</i>	<i>912</i>	<i>Description</i>	<i>Notes</i>
1	P7188800AJ	N/A	P7188800AJ	Cable Assy, 7/32" x 40'	4
2	R001284	R001284	R001292	Cover Kit	1
3	P5594700AJ	P5594700AJ	P5594700AJ	Emergency Hand Crank	
4	P7904300AJ	N/A	P7904300AJ	Pulley Block Kit	4
5	R001295	R001295	R001295	Motor Assembly	
6	P7811700AJ	P7811700AJ	P7811700AJ	Switch	
7	P7810300AJ	P7810300AJ	P7810300AJ	Power Socket	
8	P7830201AJ	P7830201AJ	P7830201AJ	Wire Harness w/ items 10 & 11	1
9	P7810500AJ	P7810500AJ	P7810500AJ	Wire Harness Plug	
10	P7837300AJ	P7837300AJ	P7837300AJ	Circuit Breaker, 60 amp	
11	R001275	N/A	R001275	Level Wind Plate	
12	R001314	R001314	R001314	Clutch Knob	
13	P7160901AJ	P7160901AJ	P7160901AJ	Clutch Spring and Washer Kit	
14	R001283	R001283	R001291	120T Gear Kit	
15	R001282	R001282	R001290	Gear Kit	
16	R001285	R001285	R001293	Shaft Kit	
17	R001281	R001281	R001289	Bearing Kit	
18	R001286	R001286	R001294	Fastener Kit	
The following repair kits are also available					
19	P91007	P91007	P91007	Drum Shaft and Gear Kit	3
20	N/A	N/A	P91008	Intermediate Shaft and Gear Kit	3
21	P91010	P91010	P91009	Rear Shaft and Gear Kit	3
22	N/A	P71892	N/A	Univeral Strap Kit	3

- Notes:**
1. Fasteners are included with kit.
  2. Fasteners and washers not indexed on illustration are part of the fastener kit (item 19).
  3. The shaft and gear kits (items 20, 21, 22) contain the respective shaft, gears, bearings and associated hardware.
  4. Included with P77712 and P77912 ONLY.

---

## WARRANTY

SFEG warrants to the FIRST retail Purchaser that the Powerwinch Product described in this manual is free of defects in material and workmanship within the terms and conditions as set forth below. SFEG's obligation under this warranty is limited to the repair or replacement, at SFEG's option, of any defective component within the stated warranty period. THIS WARRANTY IS NOT TRANSFERABLE.

### 1. Duration

- a. 1 year on parts and labor.
- b. SFEG will pay the transportation charges for return shipment to the purchaser of any product received for legitimate warranty repair.

Warranty duration is not extended by the length of time the product is not in use or the time that the purchaser is deprived the use of the product. The duration of coverage is determine by the date of the original product purchase, not the date of repairs.

### 2. What is Covered Under This Warranty?

Defects in the manufacturer's material and workmanship of product under normal use, and which occur within the duration of the warranty period.

### 3. What is Not Covered Under This Warranty?

- a. Improper installation and/or any consequent damage or failure that results from improper installation of the product.
- b. Normal wear.
- c. Conditions that are not related to the material or workmanship of the product: including any failure that results from an accident, wind, rain, or other acts of God.
- d. Purchaser's abuse, including but not limited to neglect; failure to operate, use or maintain the product in accordance with the instructions provided with the product.
- e. Any component not sold or manufactured by SFEG.
- f. Any failure that results from the use of another manufacturer's product with a SFEG product that is not specifically approved by SFEG.
- g. Any incidental, indirect, or consequential loss, damage or expense that may result from any defect, failure or malfunction of the product.
- h. The removal or alteration of any product component or device. In the event of such removal or alteration, this warranty is void.
- i. Any expense related to delivery or pick-up of product to/from the service dealer.

### 4. Responsibilities of the Purchaser

IN ORDER FOR THE WARRANTY TO BE HONORED, THE PURCHASER MUST HAVE PROOF OF PURCHASE. FAILURE TO PROVIDE THE REQUIRED DOCUMENTATION MAY DELAY OR VOID ANY WARRANTY CLAIM.

- a. Retain dated proof of purchase for the product, and provide it as requested.
- b. Perform "Periodic Maintenance" as specified in Owners Manual.
- c. Use reasonable care in maintenance, operation, use and storage of the product in accordance with the instructions contained in the owner's manual.

THIS WARRANTY GIVES THE OWNER SPECIFIC LEGAL RIGHTS. THE LAWS OF CERTAIN JURISDICTIONS MAY GRANT THE OWNER ADDITIONAL RIGHTS AND PRIVILEGES. Except as set forth above; SFEG makes no warranty, whether statutory or otherwise, including without limitation, any warranty of merchantability or fitness for a particular purpose. SFEG shall have no liability except to repair, replace or adjust defective products and parts. SFEG specifically excludes any liability, whether in contract, tort or otherwise, for personal injury, property damage, economic or consequential losses. SFEG has not authorized any person or company to alter the terms of this warranty.

It is SFEG's policy and practice to continuously improve the company's products and services. Therefore, SFEG reserves the right to make changes in design and components, without notice, whenever it is believed the quality of the product will be improved, but without incurring any obligation to incorporate such improvements in any product which has been shipped or in service.

**For Your Records**

Dealer/Installer

NAME: \_\_\_\_\_

ADDRESS: \_\_\_\_\_

\_\_\_\_\_

\_\_\_\_\_

PHONE: \_\_\_\_\_

PURCHASE DATE: \_\_\_\_\_

PART NUMBER: \_\_\_\_\_

SERIAL NUMBER: \_\_\_\_\_

PRODUCT NAME/ \_\_\_\_\_

DESCRIPTION: \_\_\_\_\_

***Retain your original proof of purchase.  
It is required for all warranty repairs and returns.***